

ies Galvaniz



تأسست شركة إيمان في أربيل سنة ١٩٨٢ ، منذ تأسيسها
باشرت في عمل المقاولات وأنجزت العديد من المشاريع
المختلفة (الجسور ، المستشفيات الطرق المدارس ، وأبنية
مختلفة) كما تخصصت في استيراد المواد الكهربائية منذ
سنة ٢٠٠٢ ، فهي وكيل معتمد لعدة شركات تركية عالمية ذات
ماركات معروفة من ضمنها (هاس جليك) لإنتاج الأسلاك
الألمنيوم والكابلات المجدولة تويست كيبل ، و (هيس كابلو
) لإنتاج الكابلات النحاسية للضغط العالي والضغط الواطي ،
إضافة لشركة (IES) لإنتاج أعمدة الكهرباء والإنارة



Iman Company for general trading of electrical was founded in 1982 in Erbil, since its foundation it started to work in contracting and have achieved many projects (bridges, hospitals, streets, schools and various buildings) after that in 2002 it specialized in importing electric materials.

Iman company is agent for Turkish companies (HASCELIK) for aluminum wire and twisted cable, (HES KABLO) for LV cables and MV cables and (IES galvaniz) for electrical poles and lightning poles.



شركة ايمان للمقاولات الكهربائية والتجارة العامة المحدودة

Mobile : +964 750 446 61 19
+964 770 446 61 19
+964 770 100 01 22
+964 750 100 91 50
+964 750 100 91 51
+964 750 555 09 88

Email : info@imancompany.net
iman_firma@yahoo.com

Company Adress : Iraq - Erbil
Kuran malchmour street
near ismail yaqube mosque

Cable warehouse Adress : Iraq - Erbil
qwer road - Erbil warehouse
complex

Cable warehouse Mobile : +964 750 290 94 95
+964 750 100 91 52

Pole warehouse Mobile : Iraq - Erbil
Kerkuk road - qushtapa

Pole warehouse Mobile : +964 750 296 81 01
+964 750 100 91 53

موبايل : +964 750 446 61 19
+964 770 446 61 19
+964 770 100 01 22
+964 750 100 91 50
+964 750 100 91 51
+964 750 555 09 88

إيميل : info@imancompany.net
iman_firma@yahoo.com

عنوان الشركة : العراق - اربيل
شارع كوران مخمور
قرب جامع اسماعيل يعقوبي

عنوان مخزن كيبيلات : العراق - اربيل
طريق گویر - مجمع مخازن اربيل

رقم مخزن كيبيلات : +964 750 290 94 95
+964 750 100 91 52

عنوان مخزن الأعمدة : العراق - اربيل
طريق كركوك - قوشتبه

رقم مخزن الأعمدة : +964 750 296 81 01
+964 750 100 91 53

**Iman Company Electrical
Contracting And
General Trading**





www.imancompany.net

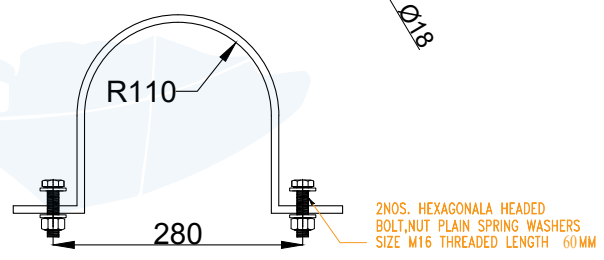
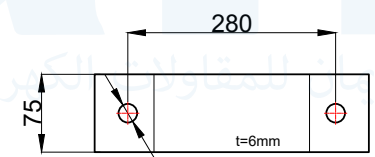
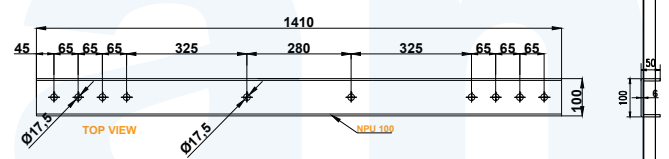
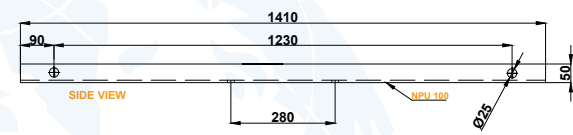
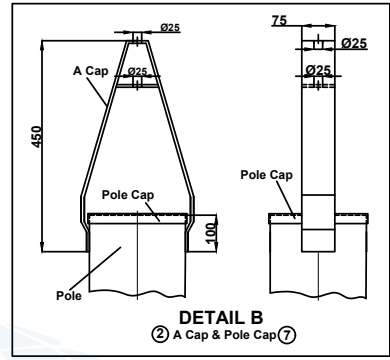
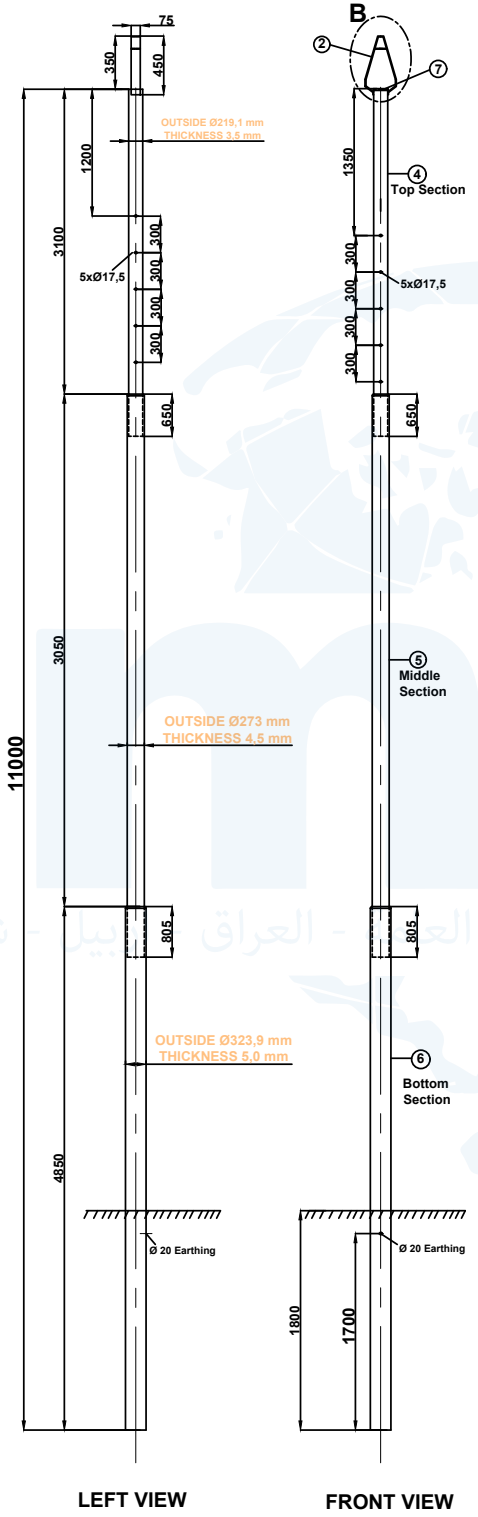



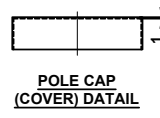
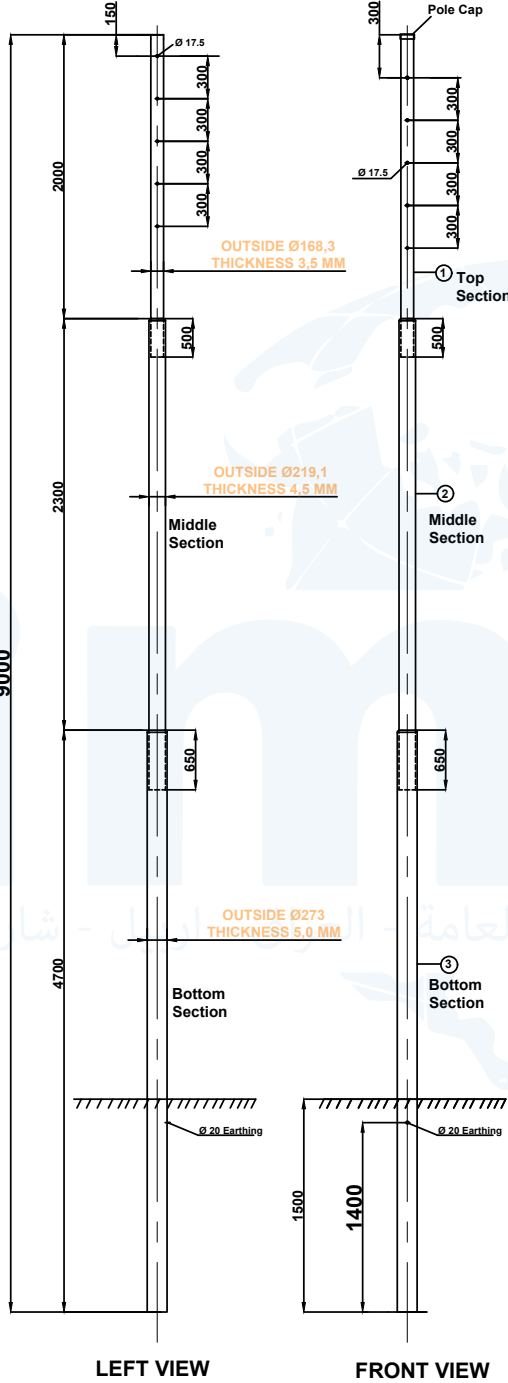

PROJE ADI	11 METER TUBULAR POLE (NORTH TYPE 1)		
SIPARIŞ NO/ ORDER NO			
HAZIRLAYAN DESIGN BY	İSİM/NAME	TARİH/DATE	İMZA/SIGN
CİZEN DRAWING BY	MEHMET YARKAÇ		
KONTROL CHECKED BY	MEHMET ÇETİN		
ONAY APPROVED BY	MEHMET ÇETİN		
			 IES GALVANİZ SANAYİ VE TİCARET ANONİM ŞİRKETİ Büyükdüysüz Mahallesi E.Ayhan Toşyalı Cad. No:11 Topçusuz Seldesi 80950 Toprakale / Osmaniye / TÜRKİYE Tel: (0328) 802 06 44 Fax: 0328 802 06 46 www.iesgalvaniz.com.tr
			SAYI/PAGE NO 1

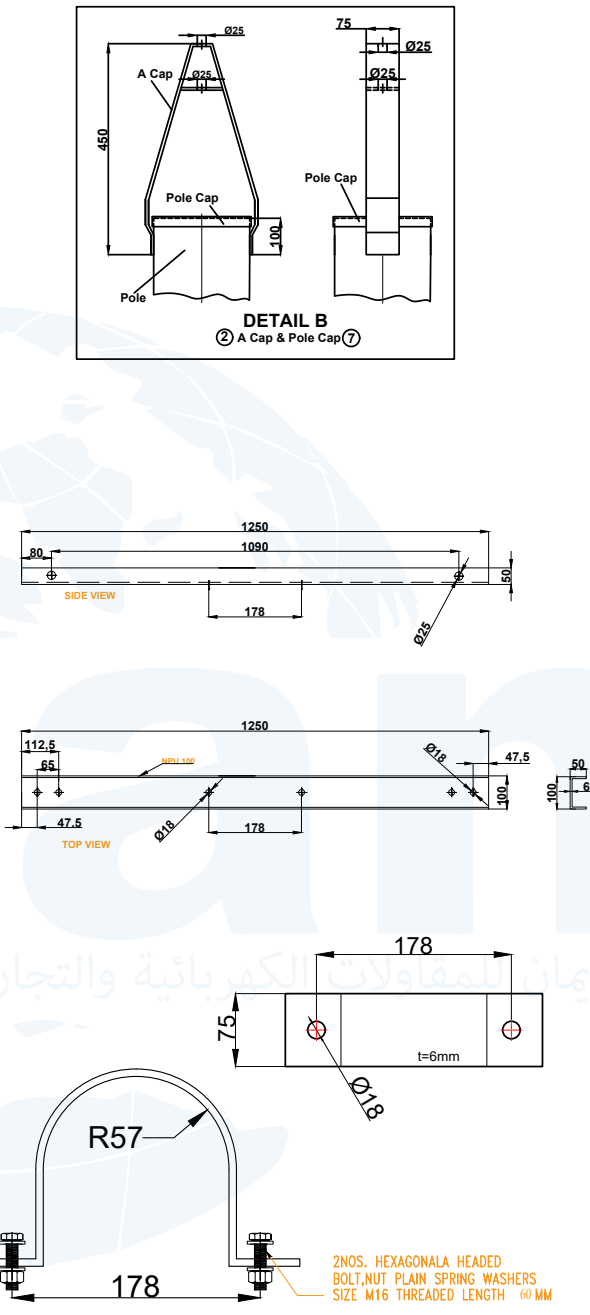
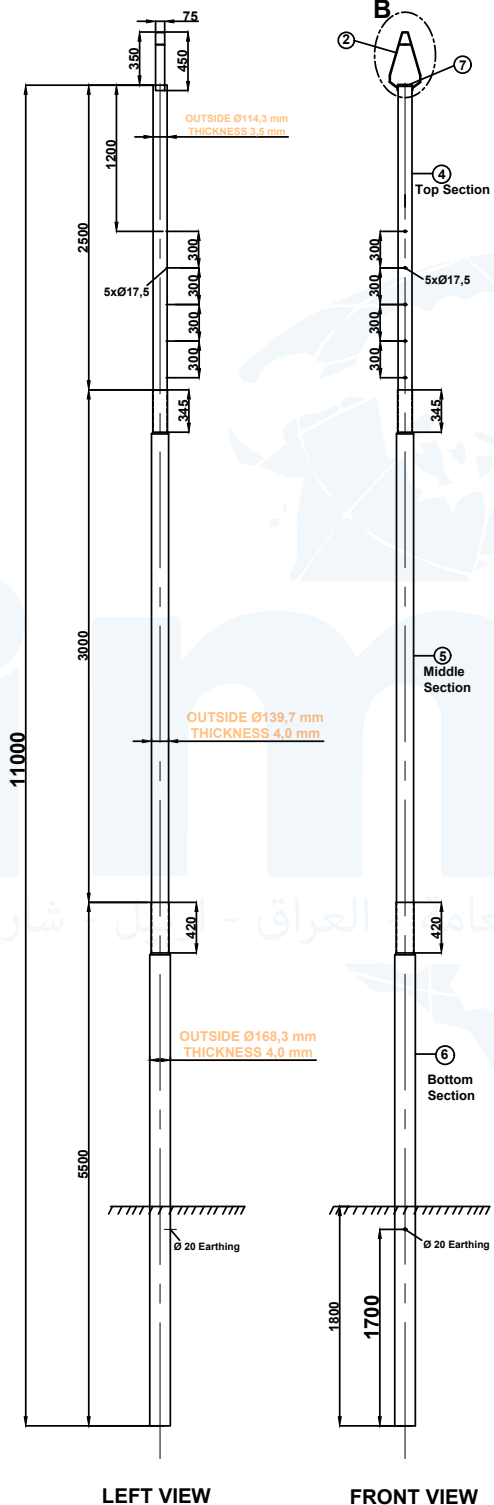

PROJE ADI		9 METER TUBULAR POLE (NORTH TYPE 2)	
SIPARIŞ NO/ ORDER NO			
İŞİM/NAME		TARİH/DATE	İMZA/SIGN
HAZIRLAYAN DESIGN BY			
CİZEN DRAWING BY	MEHMET YARKAÇ		
KONTROL CHECKED BY	MEHMET ÇETİN		
ONAY APPROVED BY	MEHMET ÇETİN		
			 IES GALVANİZ SANAYİ VE TİCARET ANONİM ŞİRKETİ Büyüktüysüz Mahallesi E.Ayhan Tosyalı Cad. No:11 Tüysüz Belediyesi 80950 Toprakale / Osmaniye / TÜRKİYE Tel:(0328) 802 06 44 Fax:0328 802 06 46 www.iesgalvaniz.com.tr
SAYI/PAGE NO			1



PROJE ADI		11 METER TUBULAR POLE (NORTH TYPE 3)	
SIPARIŞ NO/ ORDER NO			
HAZIRLAYAN DESIGN BY	İŞİM/NAME	TARİH/DATE	İMZA/SIGN
CİZEN DRAWING BY	MEHMET YARKAÇ		
KONTROL CHECKED BY	MEHMET ÇETİN		
ONAY APPROVED BY	MEHMET ÇETİN		
 SANAYİ VE TİCARET ANONİM ŞİRKETİ			Bıyıklıyüz Mahallesi E.Ayhan Tosyalı Cad. No:11 Tüysüz Beldesi 80850 Toprakale / Osmaniye / TÜRKİYE Tel:(0328) 802 06 44 Fax:0328 802 06 46 www.iesgalvaniz.com.tr
SAYFA/PAGE NO			1

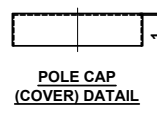
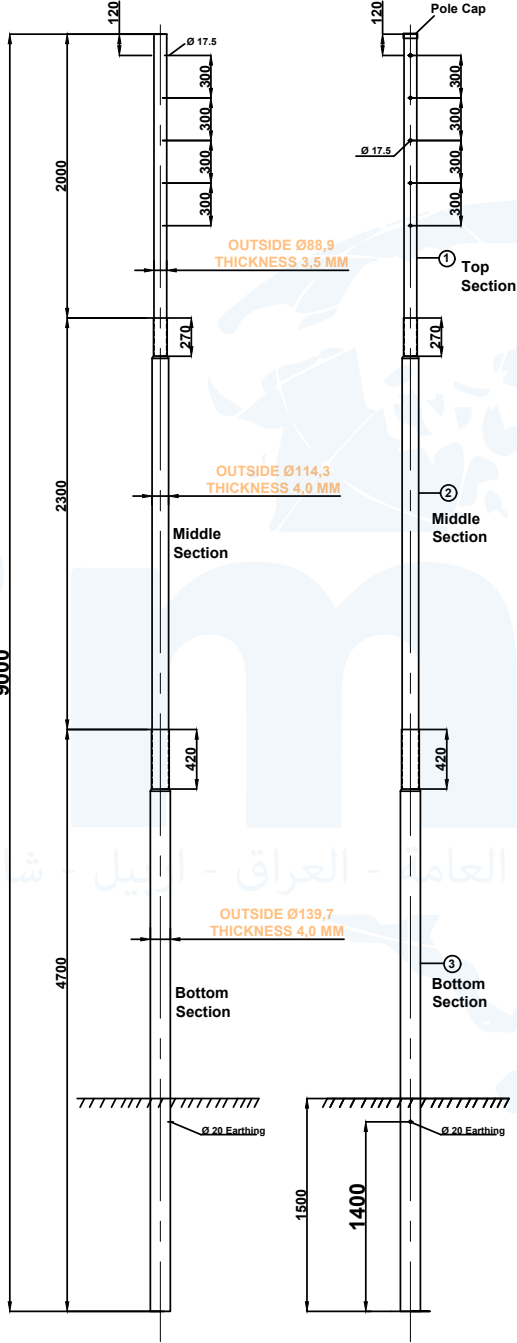

LEFT VIEW

FRONT VIEW

PROJE ADI	9 METER TUBULAR POLE (NORTH TYPE 4)		
SIPARIŞ NO/ ORDER NO			
HAZIRLAYAN DESIGN BY	İSİM/NAME	TARİH/DATE	İMZA/SIGN
CİZEN DRAWING BY	MEHMET YARKAÇ		
KONTROL CHECKED BY	MEHMET ÇETİN		
ONAY APPROVED BY	MEHMET ÇETİN		
			 IES GALVANİZ SANAYİ VE TİCARET ANONİM ŞİRKETİ Büyüktıysız Mahallesi E.Ayhan Tosyalı Cad. No:11 Tıysız Belediyesi 80950 Toprakale / Osmaniye / TÜRKİYE Tel: (0328) 802 06 44 Fax: 0328 802 06 46 www.iesgalvaniz.com.tr
			SAYI/PAGE NO 1



مخازن الأعمدة



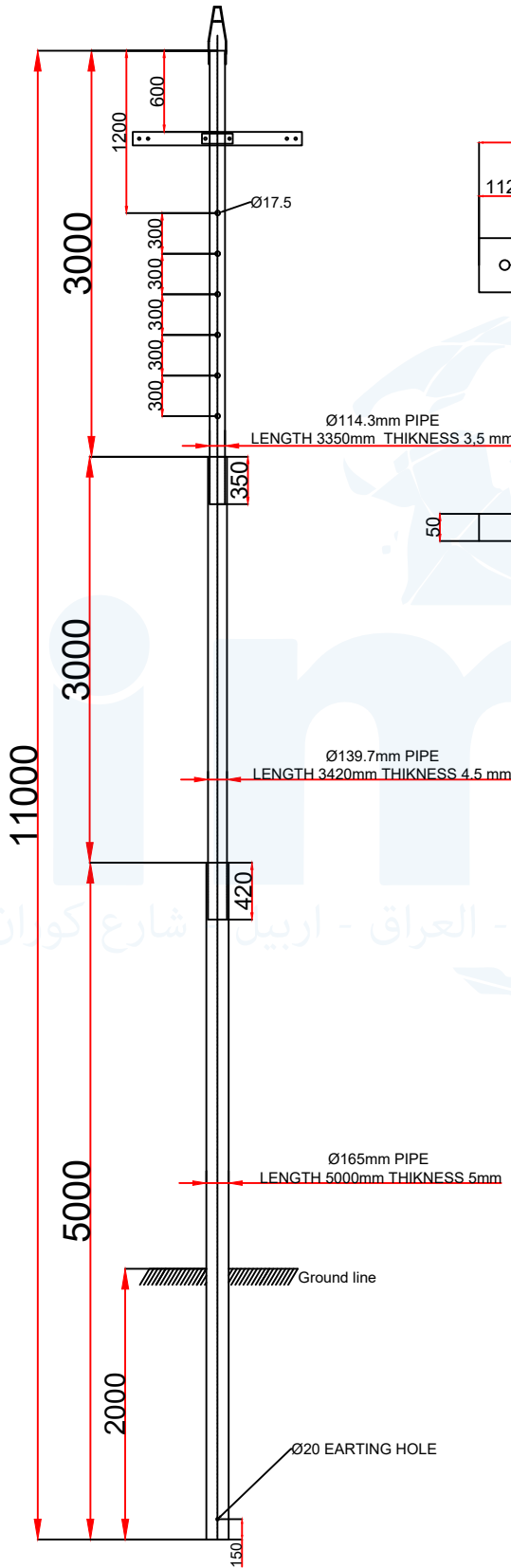

CROSS ARM DETAIL

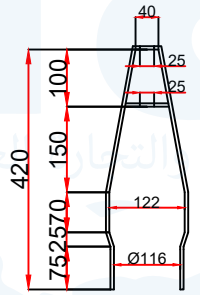
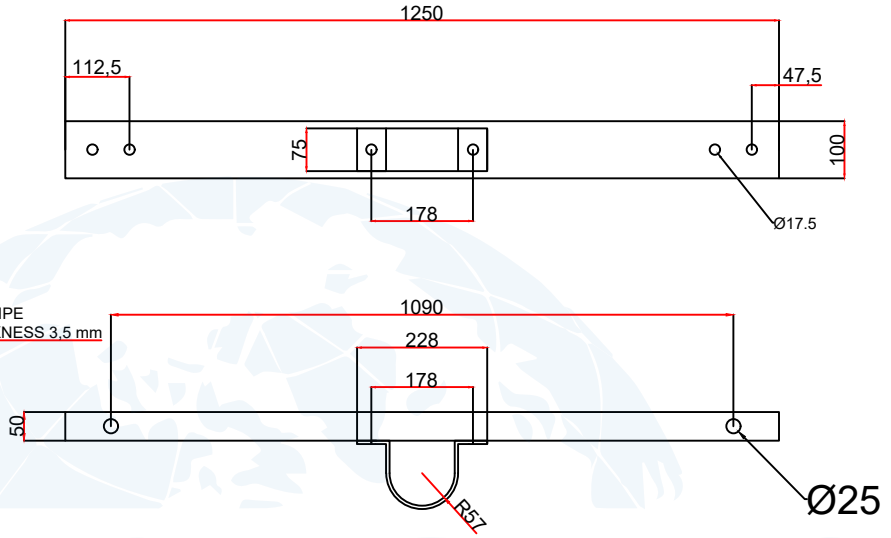

A CLAMP

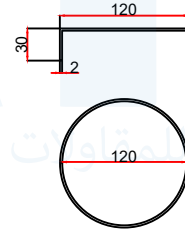

POLE CAP

PROJE ADI		11000mm TUBULAR STEEL POLE	
SIPARIŞ NO/ ORDER NO		5500024	
HAZIRLAYAN DESIGN BY	İSİM/NAME	TARİH/DATE	İMZA/SIGN
CİZEN DRAWING BY	MEHMET YARKAÇ	24.06.2021	
KONTROL CHECKED BY	MEHMET ÇETİN		
ONAY APPROVED BY	MEHMET ÇETİN		
 IES GALVANİZ SANAYİ ve TİCARET ANONİM ŞİRKETİ Büyüktüyüş Mahallesi E.Ayhan Tosyalı Cad. No:11 Tüyüş Beldesi 80950 Toprakale / Osmaniye / TÜRKİYE Tel:(0328) 952 06 44 Fax:0328 952 06 46 www.iesgalvaniz.com.tr			SAYFA/PAGE NO
			1

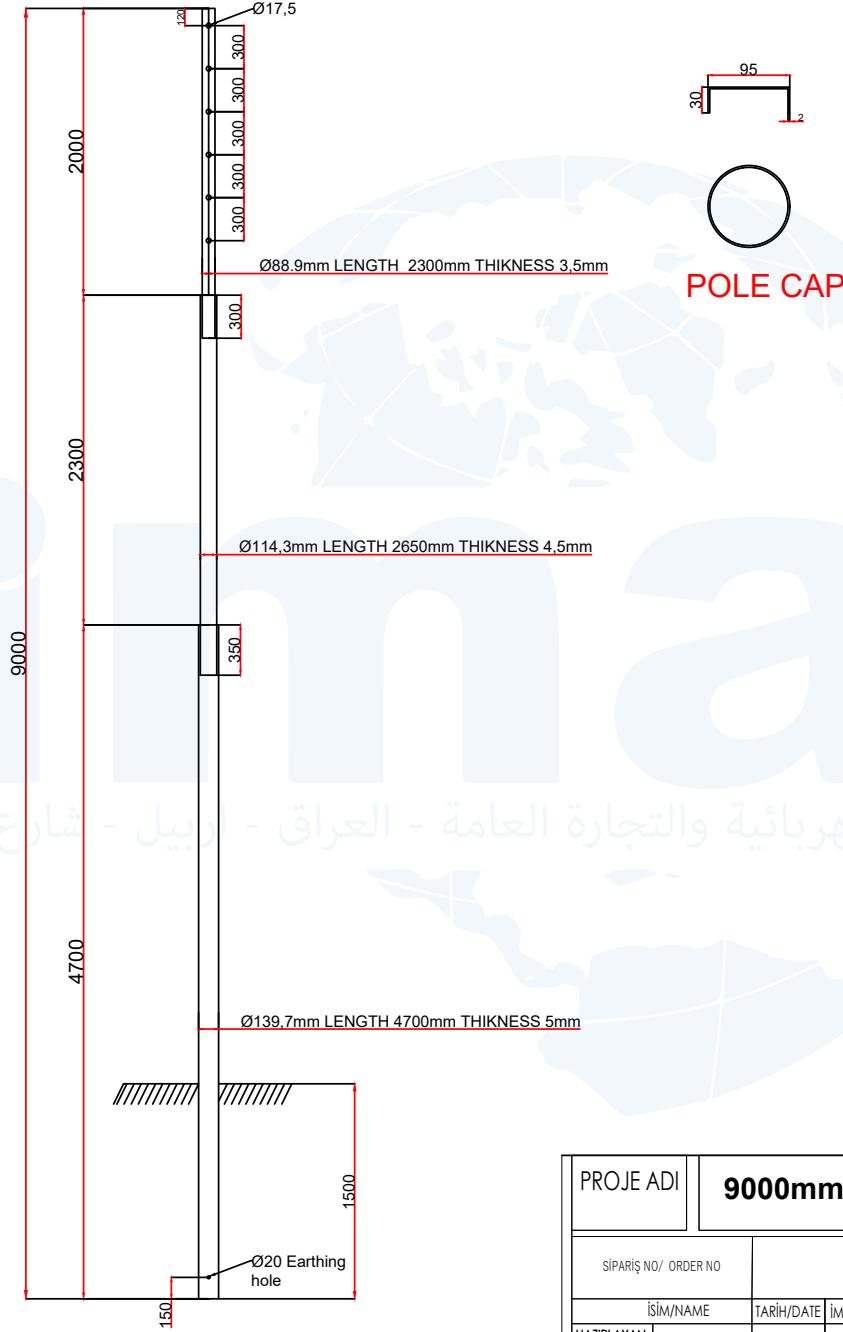

PROJE ADI	9000mm TUBULAR STEEL POLE		
SIPARIŞ NO/ ORDER NO	5500026		
HAZIRLAYAN DESIGN BY	İSİM/NAME	TARİH/DATE	İMZA/SIGN
CİZEN DRAWING BY	MEHMET YARKAÇ	24.06.2021	
KONTROL CHECKED BY	MEHMET ÇETİN		
ONAY APPROVED BY	MEHMET ÇETİN		
			 IES GALVANİZ SANAYİ ve TİCARET ANONİM ŞİRKETİ Büyüktiyemiş Mahallesi E.Ayhan Tosyalı Cad. No:11 Tüyüz Beldesi 80950 Toprakkale / Osmaniye / TÜRKİYE Tel:(0328) 802 06 44 Fax:0328 802 06 46 www.iesgalvaniz.com.tr
			SAYI/PAGE NO 1



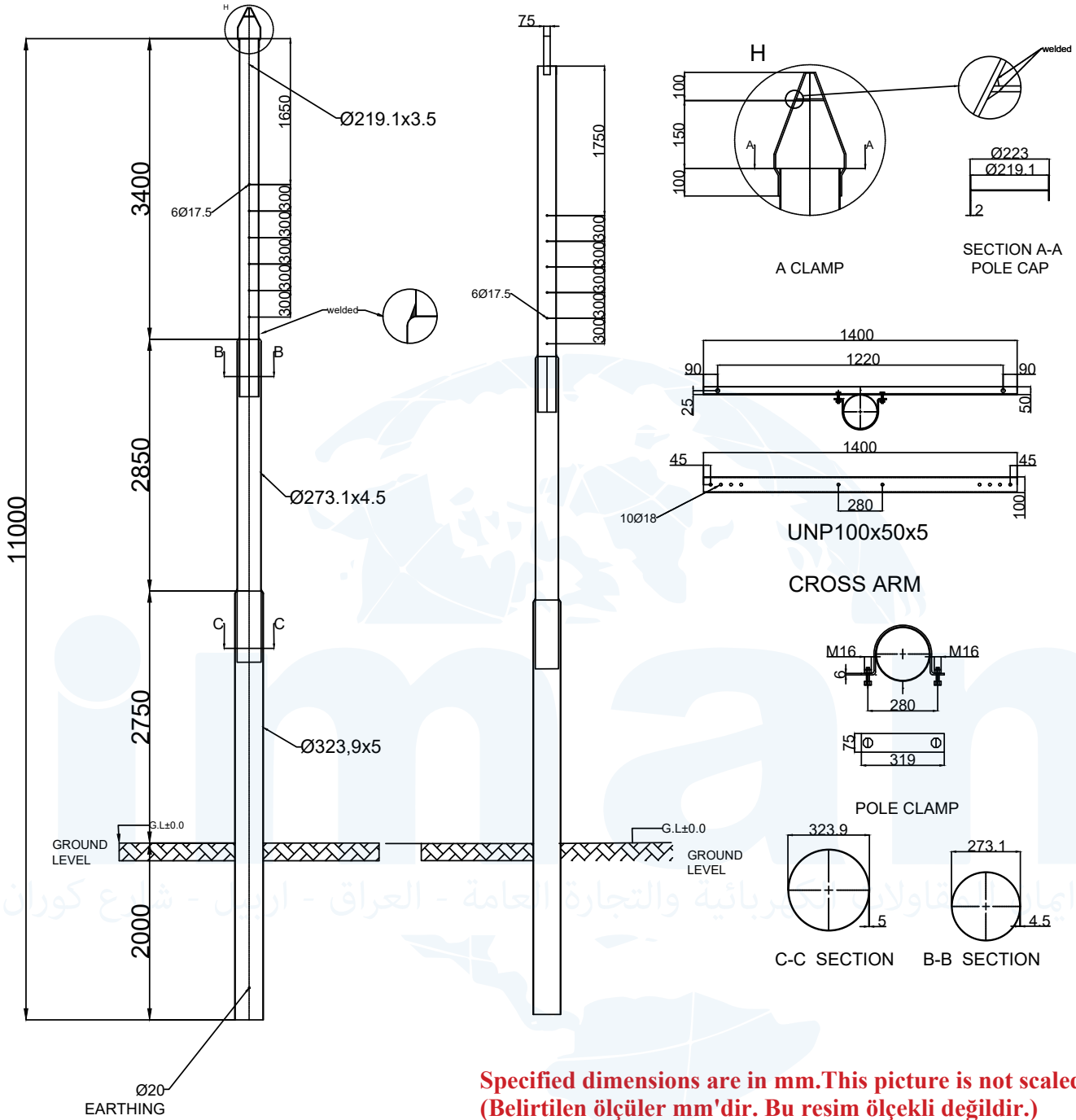

Project Name(Proje Adı): IRAK - D46-11M-2022	
Sipariş (Order)/Teklif (Offer) No:	
Total Weight (Toplam Miktar) (kg): Ör kg (±3%)	
Quality of Raw Material (Hammadde Kalitesi): ST37-2	
Quality of Welding (Kaynak Kalitesi): TSE EN ISO 3834-2	
Quality of Galvanizing (Galvaniz Kalitesi): TSE EN ISO 1461	
	File(Dosya) No: 10000001-00
	Revision Date(Revizyon Tarihi): 16.01.2023
	Prepared by(Hazırlayan): Mehmet YARKAÇ
İES GALVANİZ SAN. ve TİC. A.Ş. Büyüktüysüz Mahallesi E.Ayhan Tosyalı Cad. No:11, Türkmen Beldesi/Toprakkale/OSMANIYE/TÜRKİYE	
Page Scale (Sayfa Ölçeği): A4	
Page (Sayfa): 1/1	

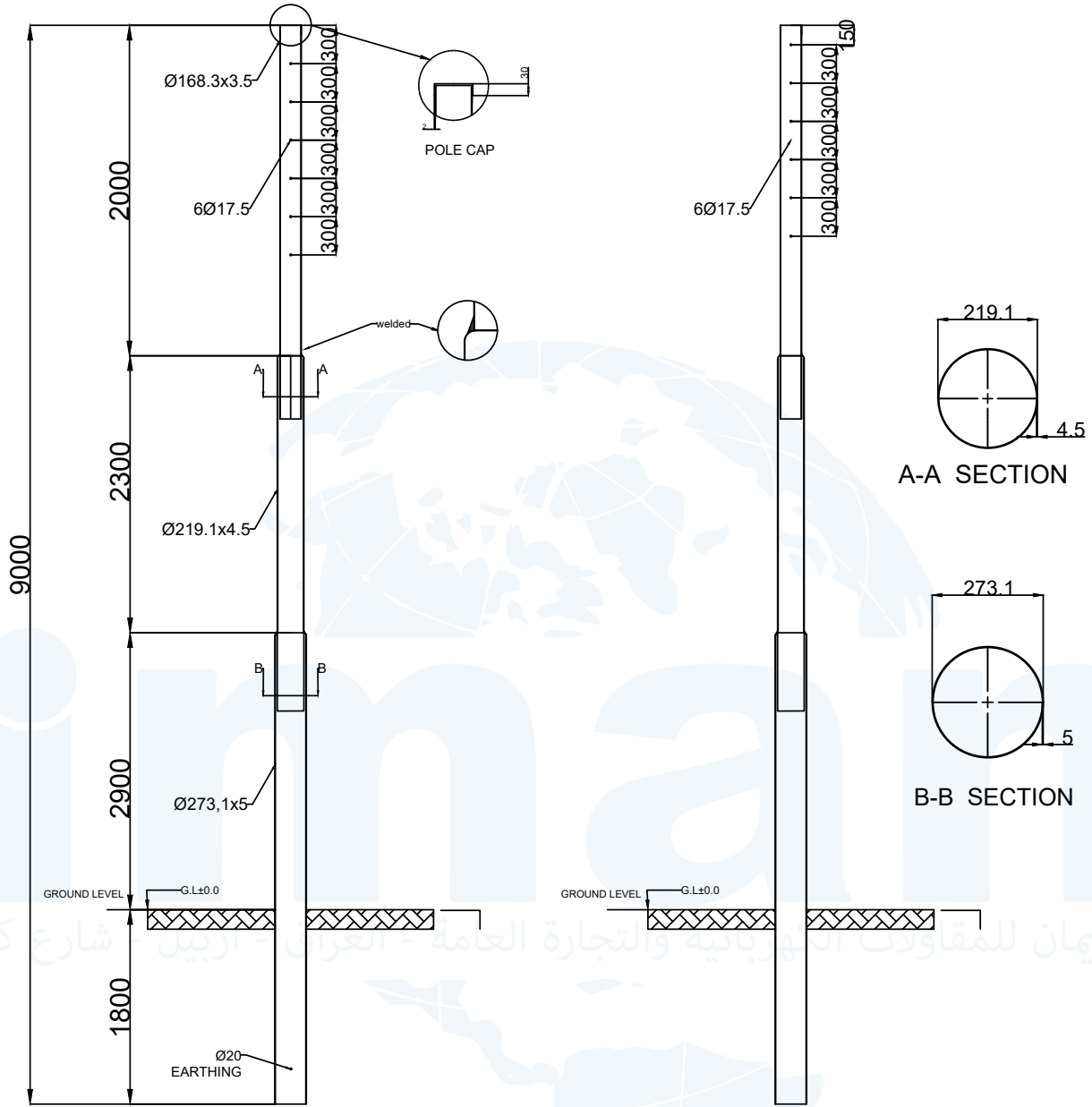

**Specified dimensions are in mm. This picture is not scaled.
(Belirtilen ölçüler mm'dir. Bu resim ölçekli değildir.)**

Project Name(Proje Adı): IRAK - D46-9M-2022	
Sipariş (Order)/Teklif (Offer) No:	
Total Weight (Toplam Miktar) (kg): Ör kg (±3%)	
Quality of Raw Material (Hammadde Kalitesi): ST37-2	
Quality of Welding (Kaynak Kalitesi): TSE EN ISO 3834-2	
Quality of Galvanizing (Galvaniz Kalitesi): TSE EN ISO 1461	
	File(Dosya) No: 10000001-00
	Revision Date(Revizyon Tarihi): 16.01.2023
Prepared by(Hazırlayan): Mehmet YARKAÇ	
İES GALVANİZ SAN. ve TİC. A.Ş. Büyüktüzsüz Mahallesi E.Ayhan Tosyalı Cad. No:11, Türkmen Beldesi/Toprakkale/OSMANİYE/TÜRKİYE	
Page Scale (Sayfa Ölçeği): A4	
Page (Sayfa): 1/1	



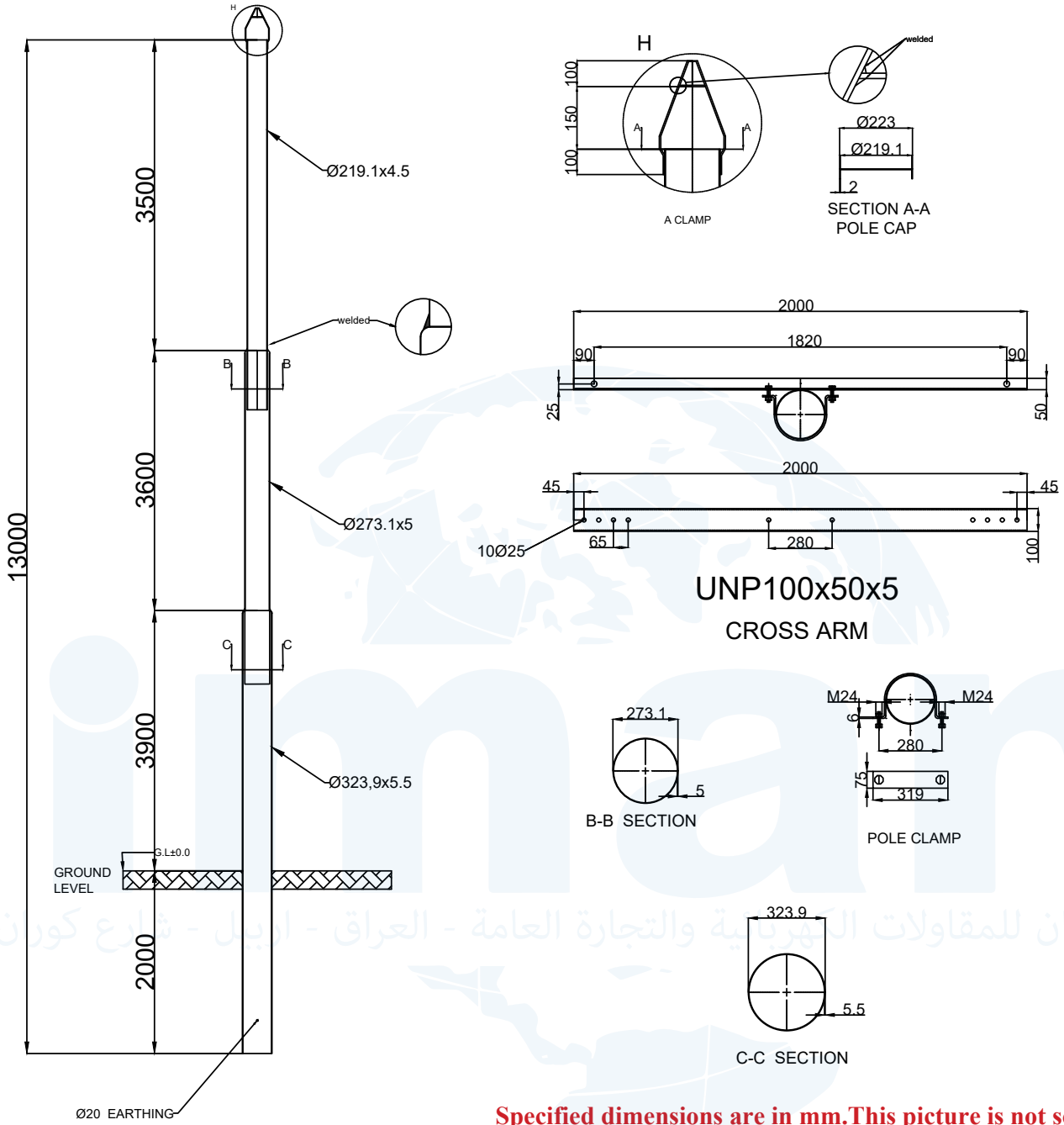

**Specified dimensions are in mm.This picture is not scaled.
(Belirtilen ölçüler mm'dir. Bu resim ölçekli değildir.)**

Project Name(Proje Adı): IRAK - D48-TYPE A(SUSPENSION)	
Sipariş (Order)/Teklif (Offer) No:	
Total Weight (Toplam Miktar) (kg): Ör kg (±3%)	
Quality of Raw Material (Hammadde Kalitesi): ST37-2	
Quality of Welding (Kaynak Kalitesi): TSE EN ISO 3834-2	
Quality of Galvanizing (Galvaniz Kalitesi): TSE EN ISO 1461	
	File(Dosya) No: 10000001-00
	Revision Date(Revizyon Tarihi): 16.01.2023
Prepared by(Hazırlayan): Mehmet YARKAÇ	
İES GALVANİZ SAN. ve TİC. A.Ş. Büyüktüysüz Mahallesi E.Ayhan Tosyalı Cad. No:11, Türkmen Beldesi/Toprakkale/OSMANİYE/TÜRKİYE	
Page Scale (Sayfa Ölçeği): A4	
Page (Sayfa): 1/1	

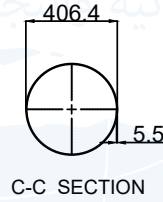
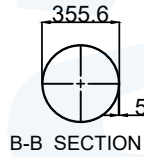
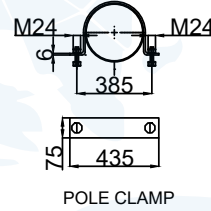
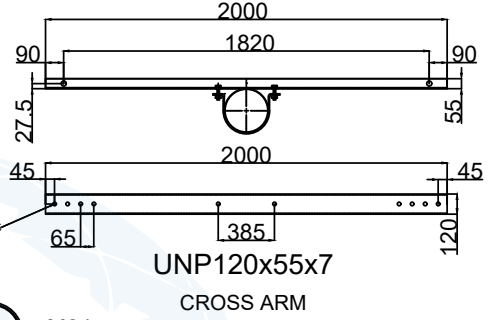
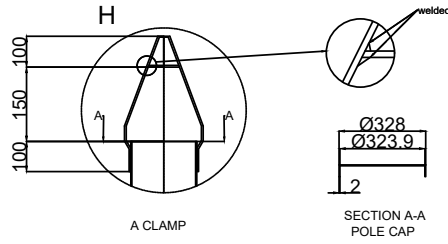
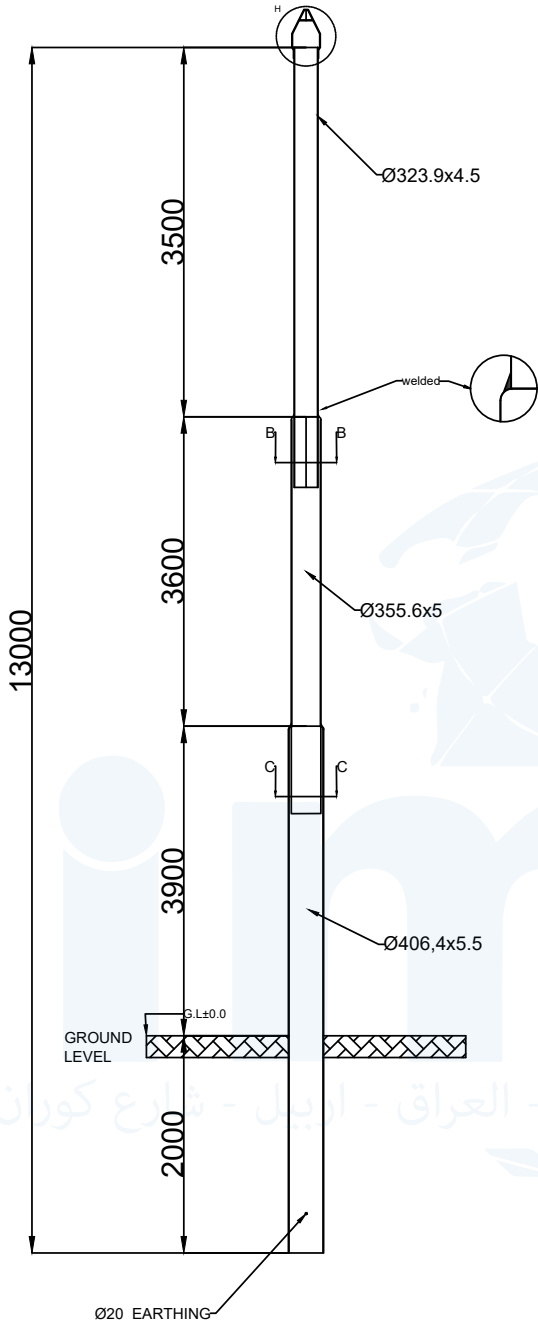

**Specified dimensions are in mm.This picture is not scaled.
(Belirtilen ölçüler mm'dir. Bu resim ölçekli değildir.)**

Project Name(Proje Adı): IRAK - D48-TYPE B(TENSION)	
Sipariş (Order)/Teklif (Offer) No:	
Total Weight (Toplam Miktar) (kg): Ör kg (±3%)	
Quality of Raw Material (Hammadde Kalitesi): ST37-2	
Quality of Welding (Kaynak Kalitesi): TSE EN ISO 3834-2	
Quality of Galvanizing (Galvaniz Kalitesi): TSE EN ISO 1461	
	File(Dosya) No: 10000001-00
	Revision Date(Revizyon Tarihi): 16.01.2023
Prepared by(Hazırlayan): Mehmet YARKAÇ	
İES GALVANİZ SAN. ve TİC. A.Ş. Büyüktüysüz Mahallesi E.Ayhan Tosyalı Cad. No:11, Türkmen Beldesi/Toprakkale/OSMANİYE/TÜRKİYE	
Page Scale (Sayfa Ölçeği): A4	
Page (Sayfa): 1/1	



GALVANİZ

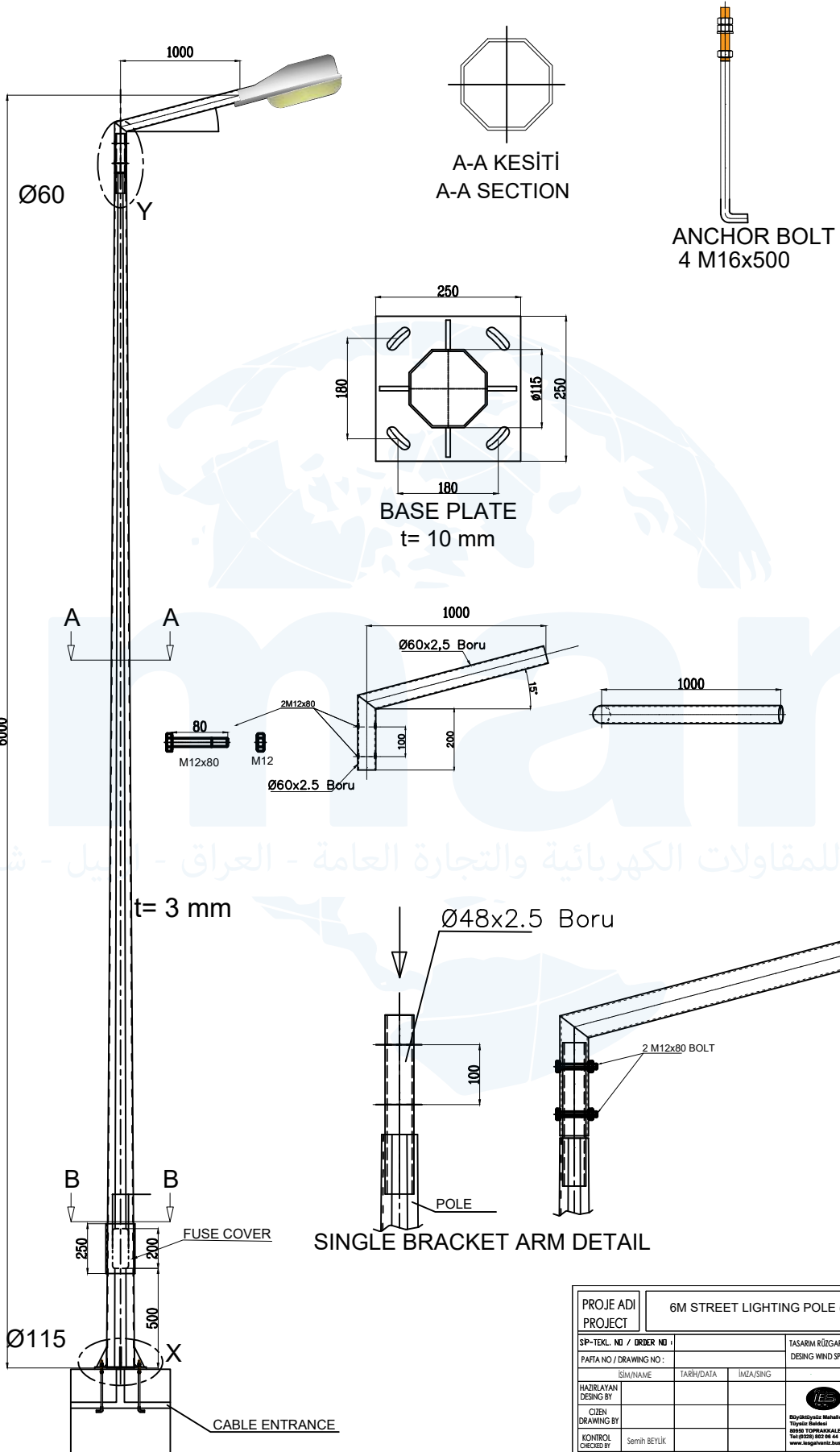

شركة إيمان للمقاولات الكهربائية والتجارة العامة - العراق - البيل - شارع كوران

PROJE ADI PROJECT		6M STREET LIGHTING POLE (AD1 60/10)	
SP-TEKL. NO / ORDER NO		TASARIM RÜZGAR HIZI DESIGN WIND SPEED	GÜVENLİK KAT SAYISI FACTOR OF SAFETY
PAFTA NO / DRAWING NO :			
SİM/NAME	TARİH/DATA	İMZA/SİNG	
HAZIRLAYAN DESIGN BY			 IES GALVANİZ <small>İSİTİM VE MÜHÜRLEME PROJELERİ</small> Büyükdere Mahallesi E. Ahañ Toprak Cad. No:11 Toprak Bölgesi 06535 TÜRKİYE / ANKARA / TÜRKİYE TEL: (0312) 882 00 44 Fax: (0312) 882 00 48 www.iesgalvaniz.com.tr
ÇİZEN DRAWING BY			
KONTROL CHECKED BY	Semih BEYLİK		
ONAY APPROVED BY			
ÖLÇÜSKALE	A3-	ŞİŞİNGİÇİ NO	1

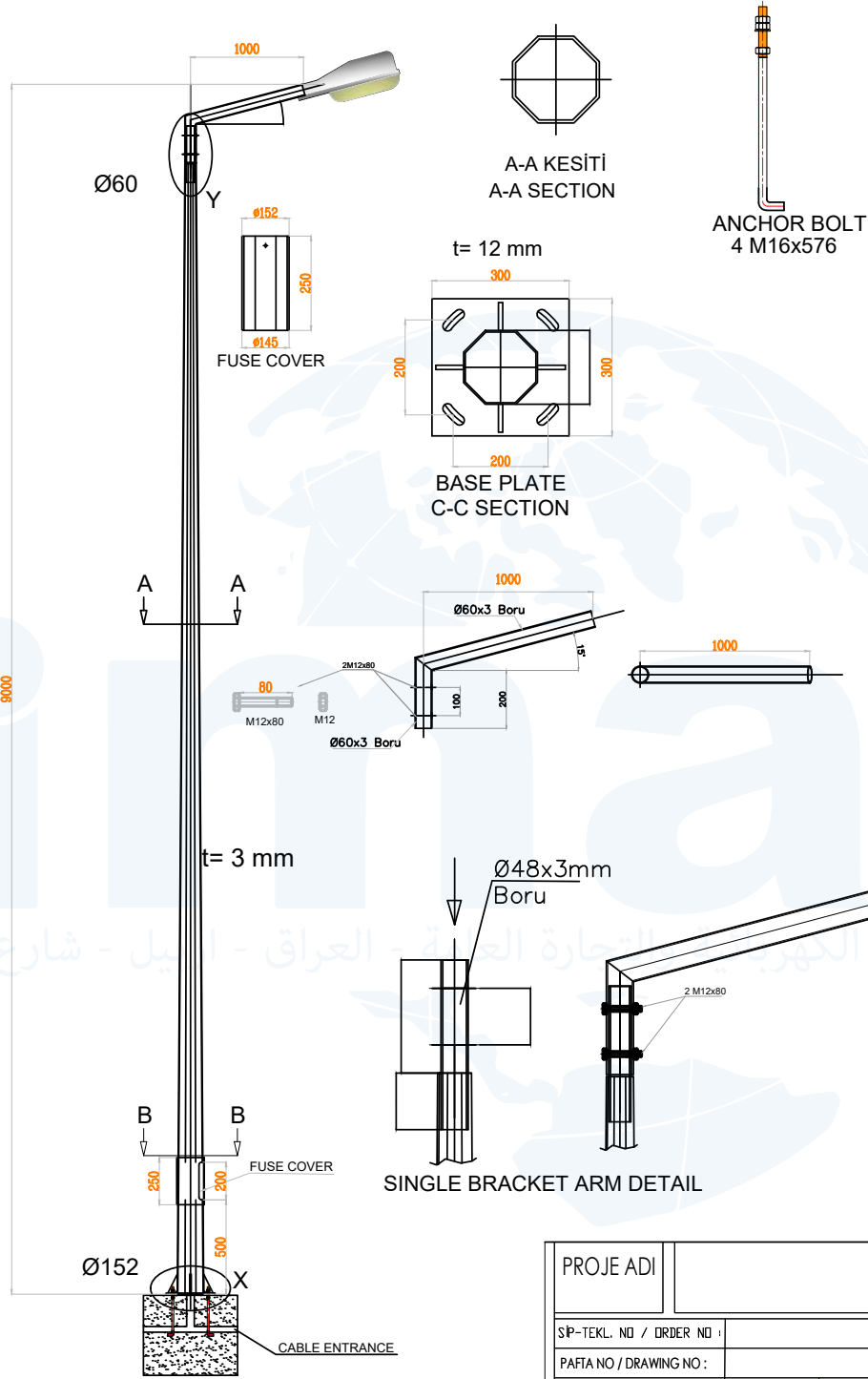

PROJE ADI			
SİP-TEKL. NO / ORDER NO :		TASARIM RÜZGAR HIZI	GÜVENLİK KAT SAYISI
PAFTA NO / DRAWING NO :		DESIGN WIND SPEED	FACTOR OF SAFETY
İSİM/NAME	TARİH/DATA	İMZA/SİNG	
HAZIRLAYAN DESIGN BY	17.02.2021		
CİZEN DRAWING BY	MEHMET YARKAÇ		
KONTROL CHECKED BY	MEHMET ÇETİN		
ONAY APPROVED BY	MEHMET ÇETİN		
		ÖLÇEK/SCALE	A3- -
		SAYI/PAGE NO	1

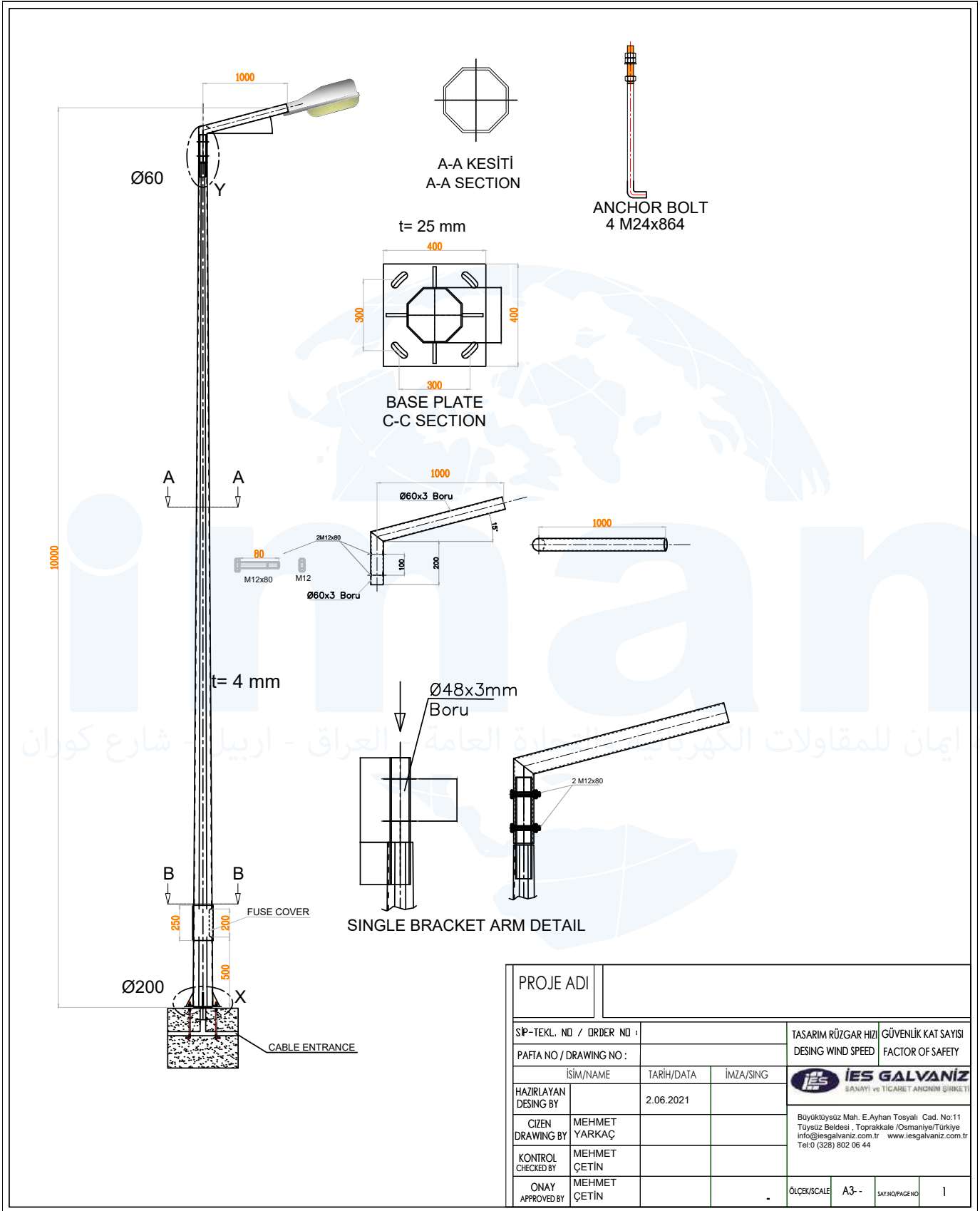

PROJE ADI			
SİP-TEKL. NO / ORDER NO :		TASARIM RÜZGAR HIZI DESING WIND SPEED	GÜVENLİK KAT SAYISI FACTOR OF SAFETY
PAFTA NO / DRAWING NO :			
HAZIRLAYAN DESING BY	İSİM/NAME	TARİH/DATA	İMZA/SING
CİZEN DRAWING BY	MEHMET YARKAÇ	2.06.2021	
KONTROL CHECKED BY	MEHMET ÇETİN		
ONAY APPROVED BY	MEHMET ÇETİN		
		ÖLÇEK/SCALE	A3- SAYI/PAGE NO 1

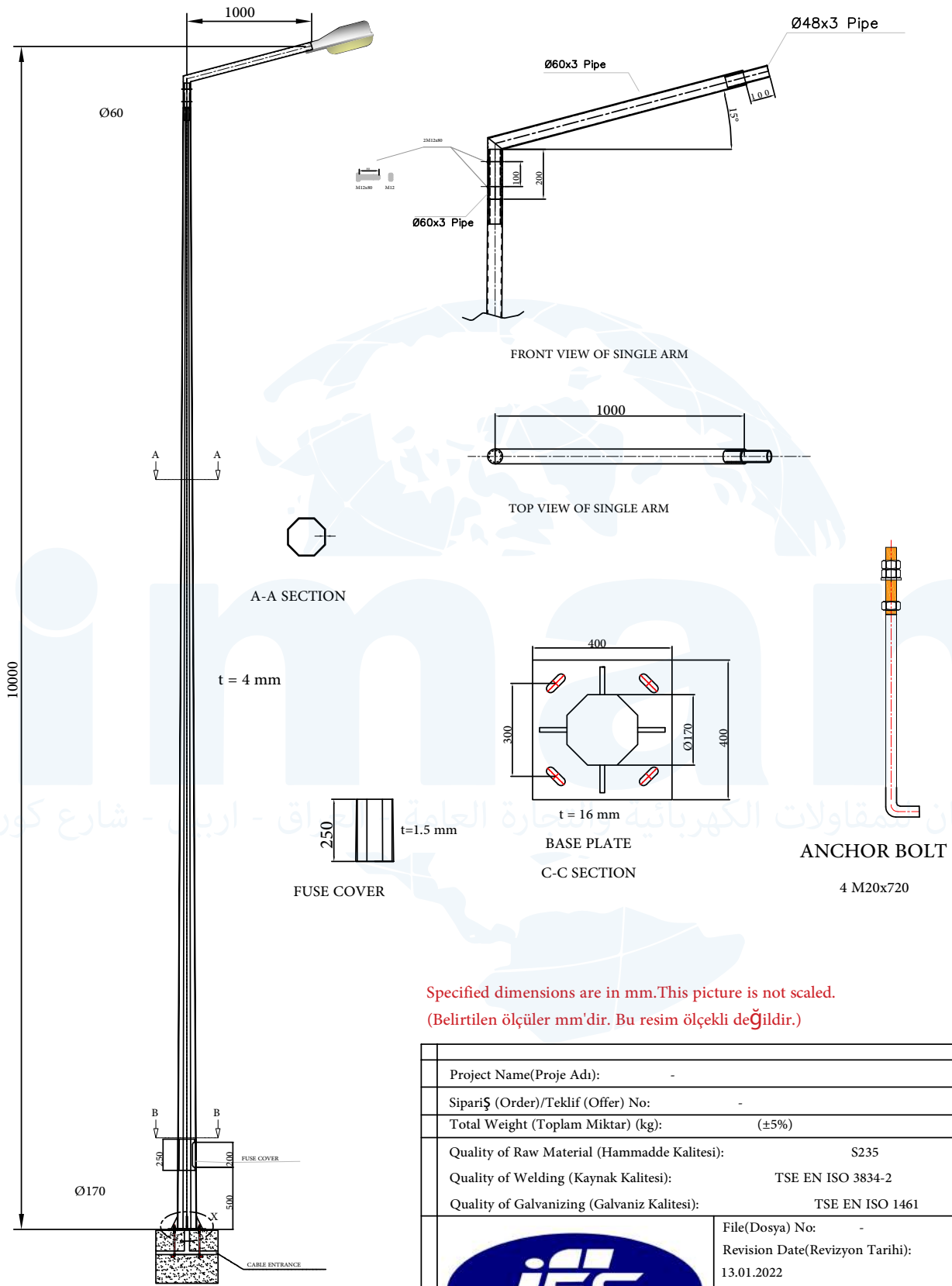

Specified dimensions are in mm. This picture is not scaled.
(Belirtilen ölçüler mm'dir. Bu resim ölçekli değildir.)

Project Name(Proje Adı):	-	
Sipariş (Order)/Teklif (Offer) No:	-	
Total Weight (Toplam Miktar) (kg):	(±5%)	
Quality of Raw Material (Ham madde Kalitesi):	S235	
Quality of Welding (Kaynak Kalitesi):	TSE EN ISO 3834-2	
Quality of Galvanizing (Galvaniz Kalitesi):	TSE EN ISO 1461	
	File(Dosya) No:	-
	Revision Date(Revizyon Tarihi):	13.01.2022
	Prepared by(Hazırlayan):	Hüseyin GÜVEN
	İES GALVANİZ SAN. ve TİC. A.Ş.	
	Büyüktüysüz Mahallesi E.Ayhan Tosyalı Cad. No:11,	
	Türkmen Beldesi/Toprakale/OSMANIYE/TÜRKİYE	
	Page Scale (Sayfa Ölçeği):	A4
	Page (Sayfa):	1/1

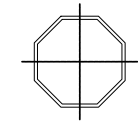
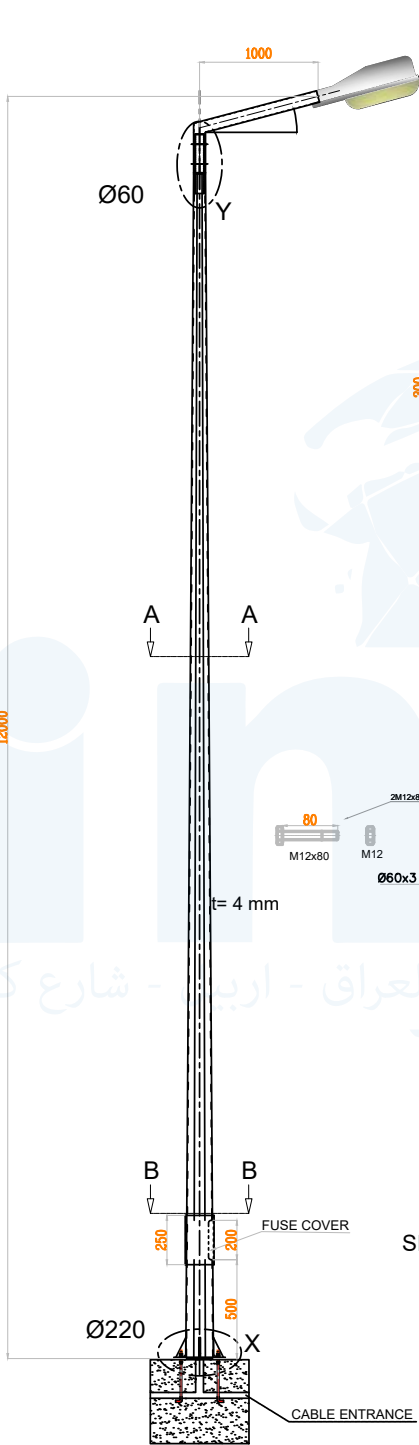

A-A KESİTİ
A-A SECTION

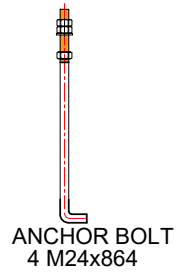

ANCHOR BOLT
4 M24x864

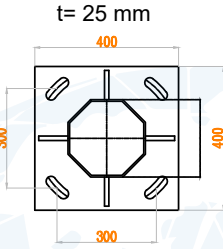

BASE PLATE
C-C SECTION

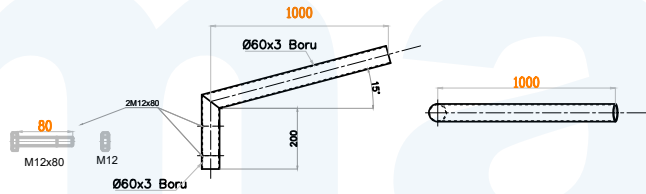

SINGLE BRACKET ARM DETAIL

PROJE ADI			
SİP-TEKL. NO / ORDER NO :		TASARIM RÜZGAR HIZI DESIGN WIND SPEED	GÜVENLİK KAT SAYISI FACTOR OF SAFETY
PAFTA NO / DRAWING NO :			
HAZIRLAYAN DESIGN BY	MEHMET YARKAÇ	TARİH/DATA 2.06.2021	İMZA/SİNG
ÇİZEN DRAWING BY	MEHMET YARKAÇ		
KONTROL CHECKED BY	MEHMET ÇETİN		
ONAY APPROVED BY	MEHMET ÇETİN		
		ÖLÇEK/SCALE	A3- - SAYI/PAGE NO 1

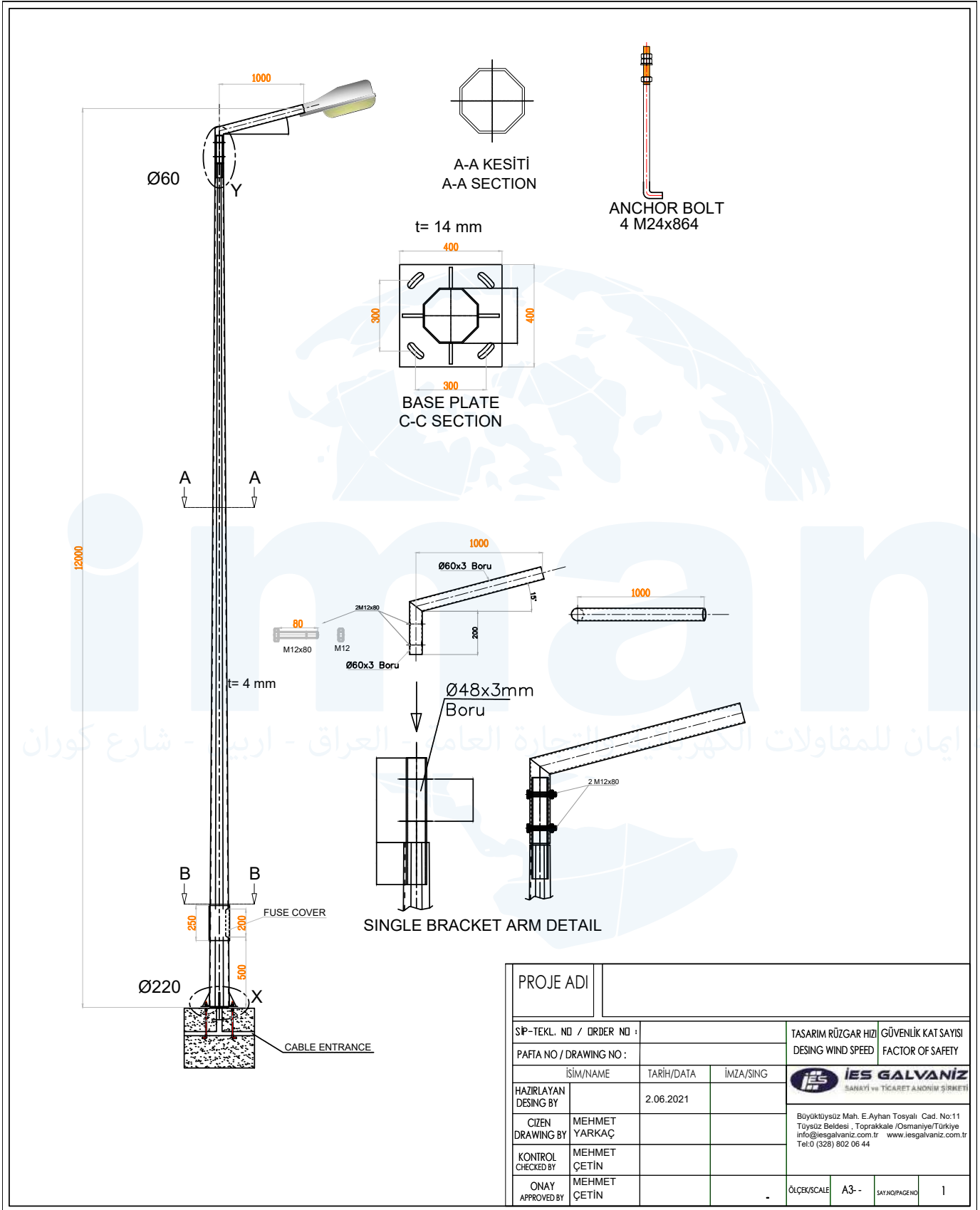

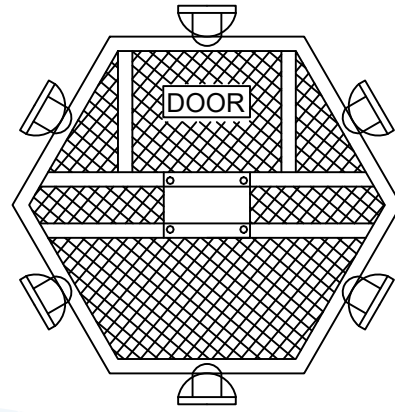
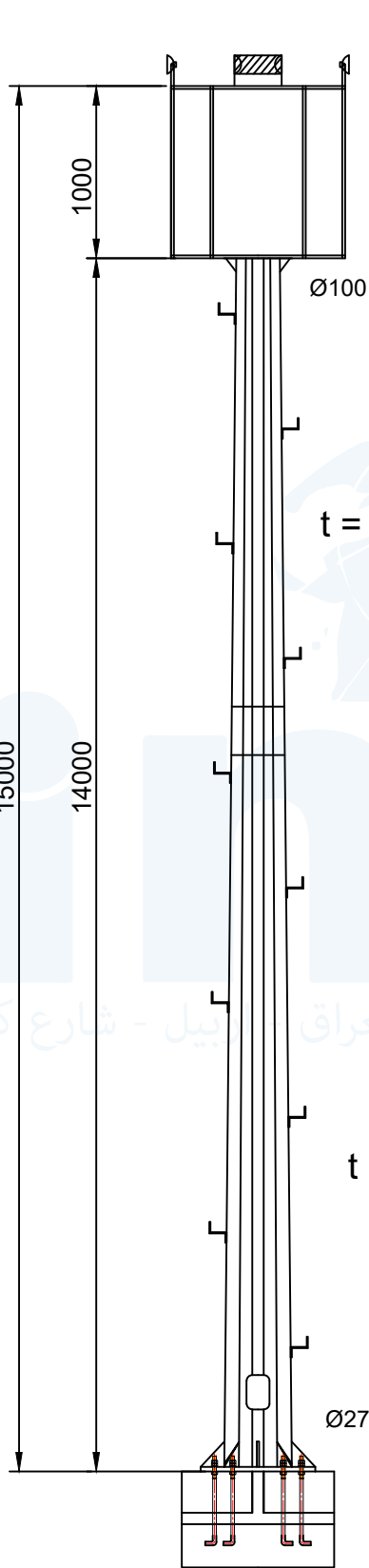

PLATFORM TOP VIEW

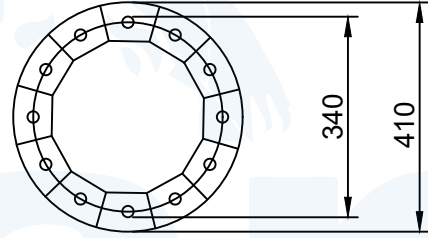

BASE PLATE
t=20 mm

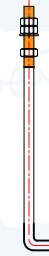

ANCHOR BOLT
4 M20x720

**Specified dimensions are in "mm". This picture is not scaled.
(Belirtilen ölçüler mm'dir. Bu resim ölçekli değildir.)**

Project Name: -	
Total Weight Tolerance: $\pm 5\%$	
Material Grade: S235	
Welding Standard: TSE EN ISO 3834-2	
Galvanizing Standard: TSE EN ISO 1461	
 <p>IES GALVANİZ</p>	File No: 00000001 Revision Date: 01.01.2022
	İES GALVANİZ SAN. ve TİC. A.Ş. Büyüktüysüz Mahallesi E.Ayhan Tosyalı Cad. No:11, Türkmen Beldesi/Toprakkale/OSMANIYE/TÜRKİYE
Page Scale: A4	
Page: 1/1	

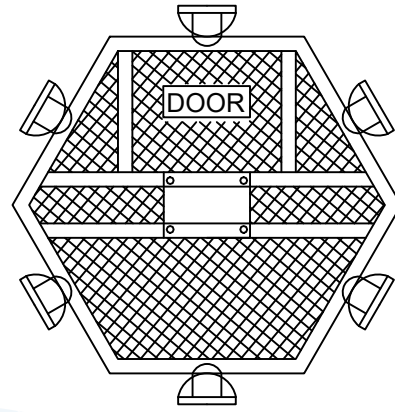
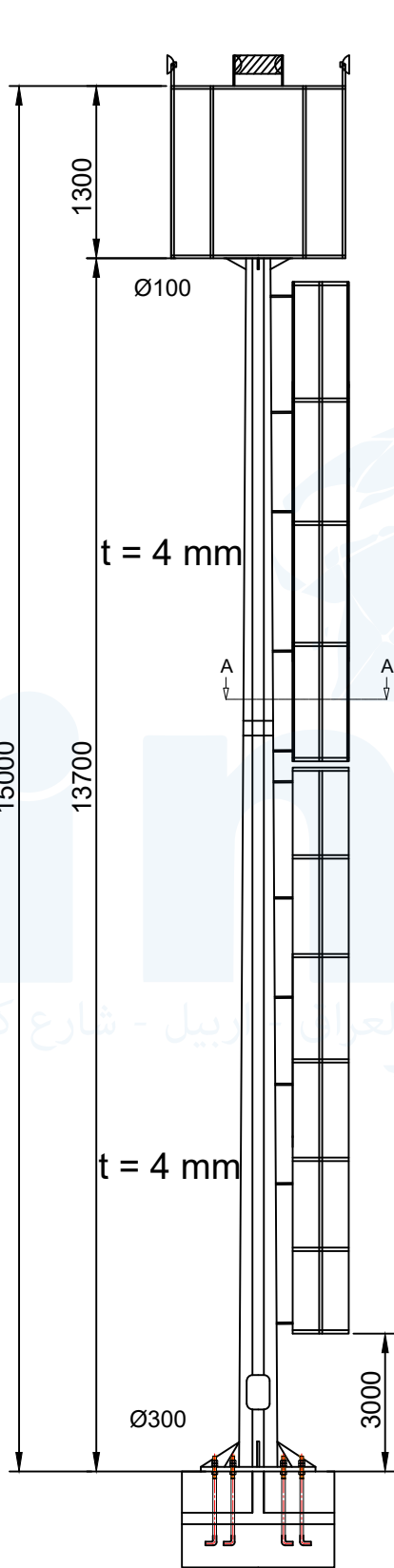

PLATFORM TOP VIEW

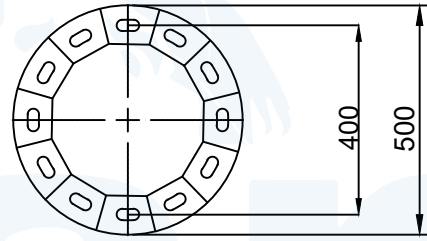

BASE PLATE
t=22 mm

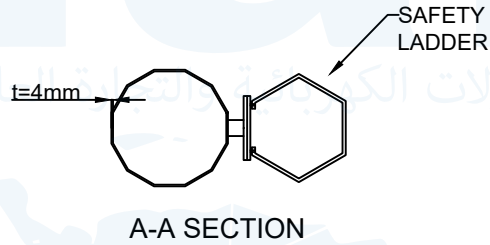

A-A SECTION

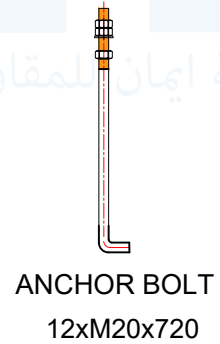

Specified dimensions are in "mm". This picture is not scaled.
(Belirtilen ölçüler mm'dir. Bu resim ölçekli değildir.)

Project Name: -	
Total Weight Tolerance: $\pm 5\%$	
Material Grade: S235	
Welding Standard: TSE EN ISO 3834-2	
Galvanizing Standard: TSE EN ISO 1461	
	File No: 00000001
	Revision Date: 01.01.2022
İES GALVANİZ SAN. ve TİC. A.Ş. Büyüktüysüz Mahallesi E.Ayhan Tosyalı Cad. No:11, Türkmen Beldesi/Toprakkale/OSMANIYE/TÜRKİYE	
Page Scale: A4	
Page: 1/1	





TÜRK STANDARDLARI ENSTİTÜSÜ
TÜRK STANDARDLARINA UYGUNLUK BELGESİ
TURKISH STANDARDS INSTITUTION
CERTIFICATE OF CONFORMITY TO TURKISH STANDARDS

Markanın Tanımı Description of the Mark
TSE veya/or  veya/or T S E

BELGE NUMARASI REFERENCE NUMBER OF LICENCE	0244496-TSE-01/01
BELGENİN İLK VERİLİŞ TARİHİ DATE OF FIRST ISSUE OF LICENCE	25.10.2018
BELGENİN SON GEÇERLİLİK TARİHİ LICENCE VALID UNTIL	25.10.2023
BELGE SAHİBİ KURULUŞUN ADI NAME OF THE LICENCE HOLDER	İES GALVANİZ SANAYİ VE TİCARET ANONİM ŞİRKETİ
BELGE SAHİBİ KURULUŞUN ADRESİ ADDRESS OF THE LICENCE HOLDER	BÜYÜKTÜYSÜZ MAH. E.AYHAN TOSYALI CAD. NO:11 TOPRAKKALE OSMANIYE/TÜRKİYE
ÜRETİM YERİ ADI NAME OF THE MANUFACTURING PLACE	İES GALVANİZ SANAYİ VE TİCARET A.Ş.
ÜRETİM YERİ ADRESİ ADDRESS OF THE MANUFACTURING PLACE	BÜYÜKTÜYSÜZ MAH.E.AYHAN TOSYALI CAD.DIŞKAPI NO:11 TÜYSÜZ BELDESİ TOPRAKKALE/ OSMANIYE / TÜRKİYE
İPTAL EDİLEN BELGE NUMARASI (Varsa) INDICATION OF SUPERSEDED LICENCE (if any)	
TESCİLLİ TİCARİ MARKASI REGISTERED TRADE MARK	iesgalvaniz
İLGİLİ TÜRK STANDARDI RELATED TURKISH STANDARD	TS EN ISO 1461 / 14.07.2011
BELGE KAPSAMI SCOPE OF LICENCE	Demir ve Çelikten Yapılmış Malzemeler Üzerine Sıcak Daldırılmalı Galvaniz Kaplamalar - Santrifüjlenmemiş Çelik Üzerine Kaplanmış ≥ 6 mm - Santrifüjlenmemiş Çelik Üzerine Kaplanmış >3 mm ≤ 6 mm - Santrifüjlenmemiş Çelik Üzerine Kaplanmış $\geq 1,5$ mm < 3 mm

e-imzalı/e-signed

25.03.2022

Belgelendirme Merkezi Başkanı Adına
FATİH KURT

TSE ADANA BELGELENDİRME MÜDÜRÜ

*Bu belge, belgelendirilen ürünün, üretim yerinin Enstitümüzün belirlediği şartları karşıladığını da gösterir.

*Bu belge, hiç bir suretle tahrif edilemez, kısmen veya okunmasını zorlaştıracak şekilde çoğaltılamaz, kazıntı ve silinti yapılamaz.

*TSE ADANA BELGELENDİRME MÜDÜRLÜĞÜ * Adres: Yakapınar Mah. D-400 Bulvarı No:174 Yüreğir * Telefon: 03224581940-41* Faks: 03224588243

*TSE BELGELENDİRME MERKEZ BAŞKANLIĞI; Adres: Necatibey Cad. No:112 06100 Bakanlıklar/ANKARA – Telefon: 0 312 416 64 81 / 416 64 27, Faks:0 312 416 66 17 E-posta :bmb@tse.org.tr , web : www.tse.org.tr



<https://evrakkontrol.tse.org.tr/BelgeDogrulama.aspx?p=hy5ps4x2> adresinden belgenin doğruluğunu ve geçerliliğini sorgulayınız.

1 / 1



Certificate

Aliment approves that for the company with the following information has established and implemented the requirements of standard of management system.

COMPANY

İES GALVANİZ SANAYİ VE TİCARET ANONİM ŞİRKETİ
BÜYÜKTÜYSÜZ MAH. E.AYHAN TOSYALI CAD.NO:11 TOPRAKKALE/OSMANİYE

STANDARD

ISO 45001:2018
OCCUPATIONAL HEALTH AND SAFETY MANAGEMENT SYSTEM

SCOPE

PRODUCTION OF ELECTRIC AND LIGHTING POLES AND BARRIERS AND GALVANIZING

Certificate No	:	012032101
Initial Assessment Date	:	12.03.2021
Registration Date	:	12.03.2021
Reissue Date	:	11.03.2022
Expiry Date	:	11.03.2024



APPROVAL





Certificate

Aliment approves that for the company with the following information has established and implemented the requirements of standard of management system.

COMPANY

İES GALVANİZ SANAYİ VE TİCARET ANONİM ŞİRKETİ
BÜYÜKTÜYSÜZ MAH. E.AYHAN TOSYALI CAD.NO:11 TOPRAKKALE/OSMANİYE

STANDARD

ISO 14001:2015
ENVIRONMENT MANAGEMENT SYSTEM

SCOPE

PRODUCTION OF ELECTRIC AND LIGHTING POLES AND BARRIERS AND GALVANIZING

Certificate No	:	E12032101
Initial Assessment Date	:	12.03.2021
Registration Date	:	12.03.2021
Reissue Date	:	11.03.2022
Expiry Date	:	11.03.2024



TÜRKAK BDS NO
YS-b131-17E0



APPROVAL



ALIMENT
CERTIFICATION

Certificate

Aliment approves that for the company with the following information has established and implemented the requirements of standard of management system.

COMPANY

İES GALVANİZ SANAYİ VE TİCARET ANONİM ŞİRKETİ
BÜYÜKTÜYSÜZ MAH. E.AYHAN TOSYALI CAD.NO:11 TOPRAKKALE/OSMANIYE

STANDARD

ISO 9001:2015
QUALITY MANAGEMENT SYSTEM

SCOPE

PRODUCTION OF ELECTRIC AND LIGHTING POLES AND BARRIERS AND GALVANIZING

Certificate No : Q12032101
Initial Assessment Date : 12.03.2021
Registration Date : 12.03.2021
Reissue Date : 11.03.2022
Expiry Date : 11.03.2024



TÜRKAK BDS NO
YS-3325-5FFD



[Signature]
APPROVAL





شركة ايمان للمقاولات الكهربائية والتجارة العامة المحدودة

Mobile : +964 750 446 61 19
+964 770 446 61 19
+964 770 100 01 22
+964 750 100 91 50
+964 750 100 91 51
+964 750 555 09 88

Email : info@imancompany.net
iman_firma@yahoo.com

**Company
Adress :** Iraq - Erbil
Kuran malchmour street
near ismail yaqube mosque

**Cable
warehouse
Adress :** Iraq - Erbil
qwer rood - Erbil warehouse
complex

**Cable
warehouse
Mobile :** +964 750 290 94 95
+964 750 100 91 52

**Pole
warehouse
Mobile :** Iraq - Erbil
Kerkuk rood - qushtapa

**Pole
warehouse
Mobile :** +964 750 296 81 01
+964 750 100 91 53

موبايل : +964 750 446 61 19
+964 770 446 61 19
+964 770 100 01 22
+964 750 100 91 50
+964 750 100 91 51
+964 750 555 09 88

إيميل : info@imancompany.net
iman_firma@yahoo.com

**عنوان
الشركة :** العراق - اربيل
شارع كوران مخمور
قرب جامع اسماعيل يعقوبي

**عنوان مخزن
كيبلات :** العراق - اربيل
طريق گویر - مجمع مخازن اربيل

**رقم مخزن
كيبلات :** +964 750 290 94 95
+964 750 100 91 52

**عنوان مخزن
الأعمدة :** العراق - اربيل
طريق كركوك - قوشتپه

**رقم مخزن
الأعمدة :** +964 750 296 81 01
+964 750 100 91 53

**Iman Company Electrical
Contracting And
General Trading**

www.imancompany.net

